



# Crystal Oscillators

OCXO/14PIN-DIP/±100ppb/-20~+70°C  
19.600MHz/3.3V/AS019600AA

## Description

AS019600AA is Oven Controlled Voltage Controlled Crystal Oscillator(OCVCXO) of the DIP-14pin(SMD 7×5mm) package. OCXO Series can be output to 6-160MHz by Operating Voltage:3.3V(Oscillation) and 3.3V(Oven Heater:0.33w)in the heaterpower supply. As for the frequency stability level, ±100ppb is -20~+70°C possible.

## Feature

- 20.8×13.2×8mm 14PIN-DIP PKG
- Frequency stability:±100ppb/-20~+70°C/3.3V±5%
- Frequency short term stability:Warm up/10sec
- Phase noise:-90dBc/10Hz,-150dBc/1KHz, at 10MHz
- Phase Jitter:≤0.1psec RMS(10Hz to 10MHz)
- Excellent aging characteristics:±500ppb/Y/30days
- Power consumption:3mA(OSC),100mA(Heater)/3.3V
- Operating temperature : -20~+70°C,-40~+85°C

## Applications

- Mobilephone Base station
- Measuring instrument
- Exchanger
- High-end router

## Product Number: AS019600AA

AS	019600	O:Function Series	A:Package	A:Version
Compy Code	Frequency 19.600MHz (6~160MHz)	O:SMD OCVCXO	14PIN-DIP 20.8×13.2 ×8mm	A:-20~70°C ±100ppb,3.3V (0.33W)

## Specifications

ITEMS	TYPE	AS019600AA
Output Frequency:		19.600000MHz
Frequency Stability		±100ppb:-20 to +70°C/Vdd=3.3V+/-5%
Initial supply voltage tolerance		±10ppb:Vdd=3.3V±5%
Initial load change tolerance		±10ppb:Vload:±5%
Initial aging tolerance/day		±5ppb:after 30 days of operation
Initial aging tolerance/year		±250ppb:after 30 days of operation
Warm-up time		10sec:to ±100ppb/final frequency/1 hour after/25°C
Phase Noise		Typ:-90dBc/10Hz,-120dBc/100Hz,-150dBc/1KHz at 10MHz
PhaseJitter		≤0.1psec RMS(1KHz to 20MHz)
Operating Temperature Range		-20 to +70°C
Storage Temperature Range		-40 to +85°C
Power SupplyVoltage/Oscillation		3.3V±5%
Power SupplyVoltage/Oven heater		3.3V±5%
Power Consumption/Oscillation(No load)		Typ:3.0mA/3.3V,Max:5.0mA/3.3V
Power Consumption/Oven Heater		Typ:100mA/3.3V,Max:250mA/3.3V
Input Level		Min:VIH :+0.9Vdd, Max:VIL :+0.1Vdd
Output Level/CMOS		Min:VOH:+0.9Vdd, Max:VOL:+0.1Vdd
Output Load		15pF
Output Rise/Fall Time		5nsec max(0.3 to 3.0V)/5nsec max(3.0 to 0.3V)
Assembly Temperature Range		Dip soldering temperature 230 ±10°C for 5±1sec

## Block Diagram

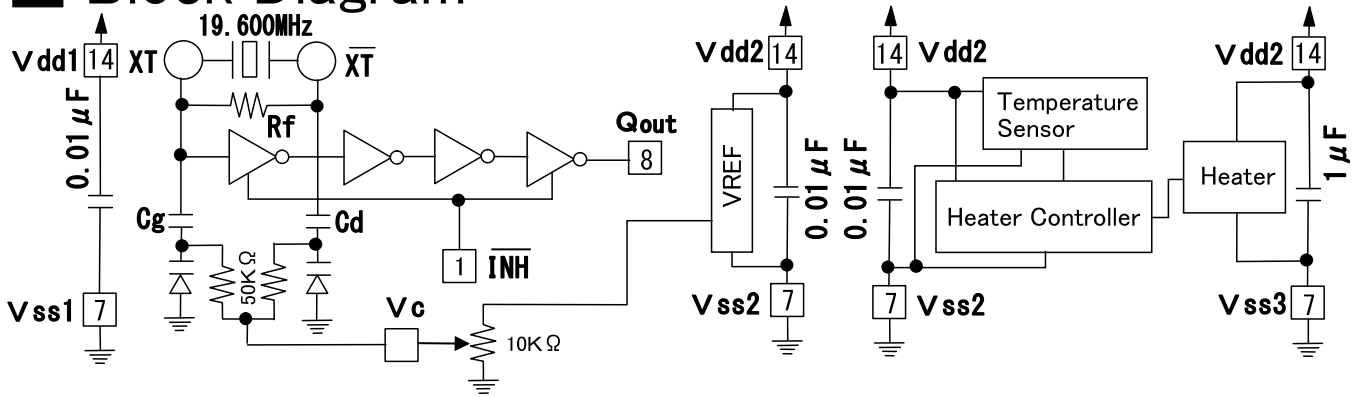

## Dimensions

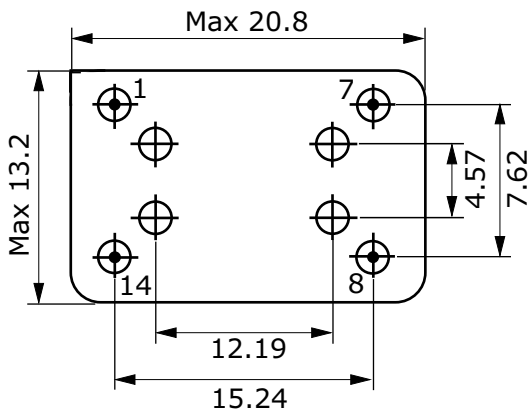
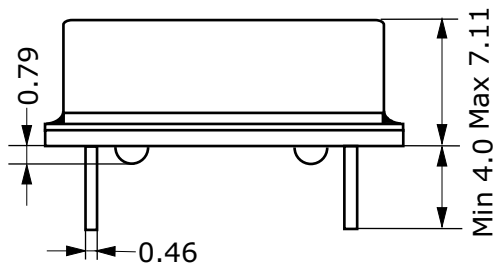
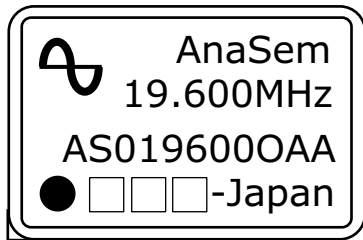

## Measurement Circuit

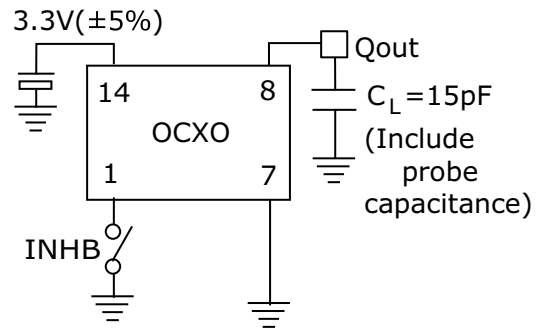

## Pin Connections

1	INHB
7	GND(Vss)
8	Output
14	+3.3V(VDD)

## Package



/INHIBIT	
"L"Level	Open or "H"Level
High Impedance	Enable:Output

## AnaSem. InC

2-13-10 Maehara Nishi Funabashi Chiba Japan  
 TEL (047) 470-5810 FAX470-5825  
 Home Page: <http://www.anasem.co.jp>  
 e-mail: support@anasem.co.jp