



AnaSem Analog Semiconductor IC VRH Series

High Speed/Low Dropout/High Accuracy CMOS Positive Voltage Regulator

Description

The VRH Series is a positive voltage regulator where high speed low dropout and highly accurate output were achieved by low current consumption. The output voltage guarantees $\pm 1\%$ within the range of all temperatures by V_{ref} that the temperature characteristic is controlled. It corresponds to the low ESR capacitor as an output stabilization capacitor. The charged ESR capacitor can be discharged with an internal switch by making the $CE = V_{ss}$, as a result the V_{out} quickly returns to the V_{ss} level. To make the current capacity of the output transistor not exceeded, the overcurrent protection circuit is built in.

Feature

- Output voltage: 0.9~5.0V (Selectable 50mV Step)
- Operating voltage range: 1.6V~6.0V
- High accuracy output voltage: $\pm 1\%$ (-40~85°C)
- Maximum output current: 250mA
- Dropout voltage: 90mV (Output: 3.0V I_{out} : 100mA)
- Low current consumption: Typ/25 μA
- High ripple rejectin: Typ/75dB at 1KHz
- Low ESR capacitor : 1.0 μF ceramic capacitor
- Operating temperature range: -40 to 85°C
- Built-in overcurrent protector
- CL High-Speed Auto-Discharge: B/Version
- Small package: SOT-25(400mW) SSOT-24(350mW) LLP-4(600mW)

Applications

- Battery powered-devices
- Cellular phones
- Digital/Video cameras
- Portable games
- Handheld instruments

Product Number: VRH3051NTA VRH3051NSA, VRH3051NLA

VRH	3051: Output Voltage Spec	N/L: Function Spec	T/S/L: Package	A: Version B: Version
AnaSem V/R H-Series	305: 3.05V/Vout 1: $\pm 1\%$, 2: ± 20 mV/Accuracy	N: Input/2.05~6.0V Output/1.95~5.0V L: Input/0.9~2.0V Output/0.8~1.9V	T: SOT-25 S: SSOT-24 L: LLP-4	A: Non/B: Discharge

Pin Configuration

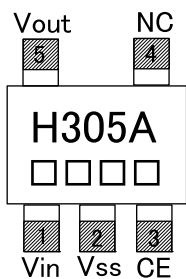

Pin	Name	Description	Pin
1	Vin	Input Voltage	4
2	Vss	Power Ground	2
3	CE	Chip Enable	1
4	NC		
5	Vout	Output	3

SOT-25 Top View

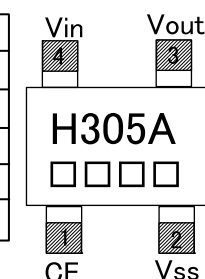

SSOT-24 Top View

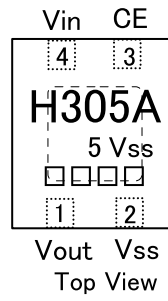

LLP-4

Pin	Name	Description
1	Vout	Output
2	Vss	Power Ground
3	CE	Chip Enable
4	Vin	Input Voltage
5	Vss	Power Ground

Block Diagram

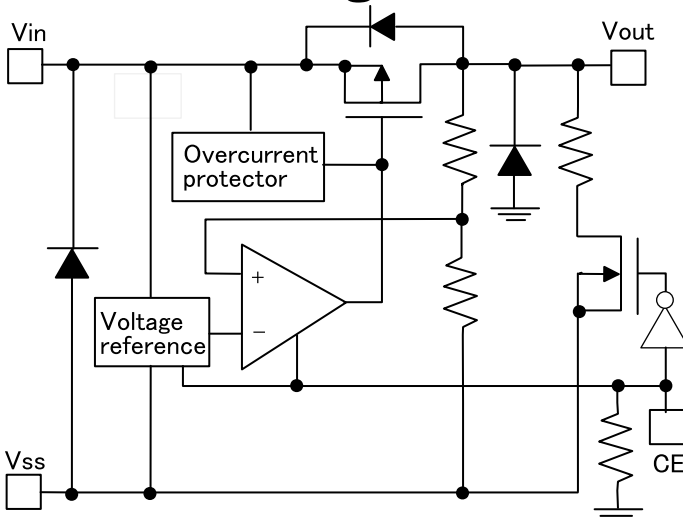

Typical Application

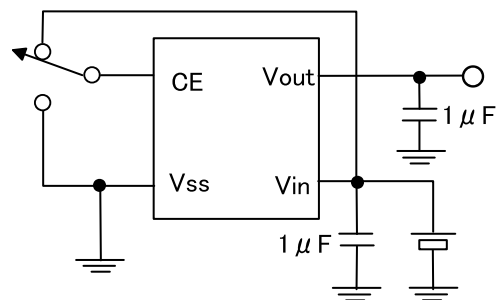

Package Size

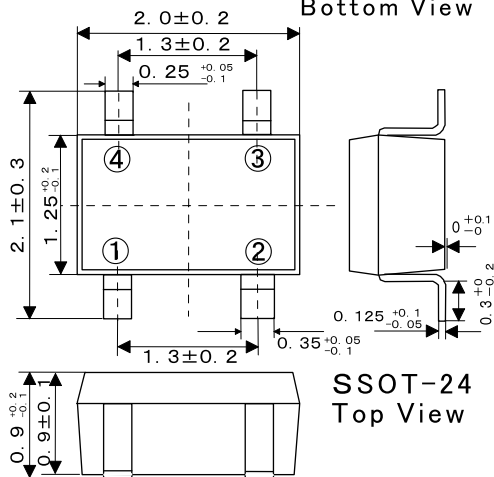
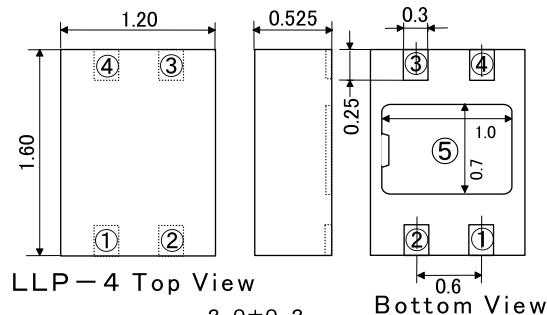
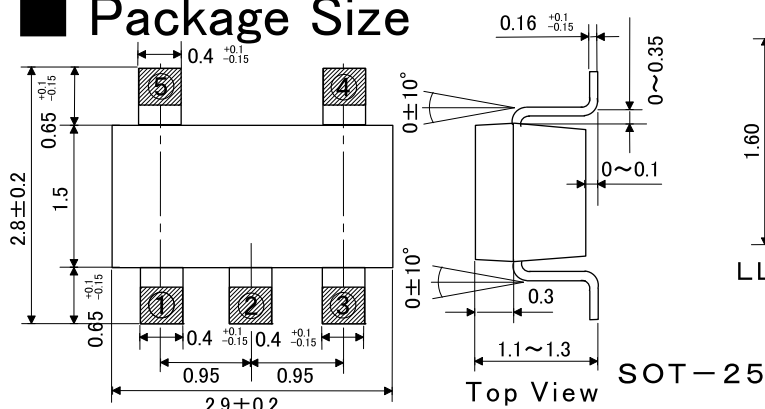

Absolute Maximum Rating

Item	Sign	Value
Input Supply Voltage	Vin	-0.3V~+7.0V
Output Current	Iout	500mA
Output Voltage	Vout	Vss-0.3V~Vin+0.3V
Power Dissipation	SOT-25	Pd 400mW (ON PCB)
	SSOT-24	Pd 350mW (ON PCB)
	LLP-4	Pd 600mW (ON PCB)
Operating Temperature Range	Topr	-40~+85°C
Storage Temperature Range	Tstg	-50~+125°C

Electric Characteristics

Ta=25°C

Item	Symbol	Measurement condition	Spec			Unit
			Min	Typ	Max	
Output voltage	Vout	Vout+1.0V ≤ Vin ≤ 6.0V, Iout=30mA, -40°C ≤ Ta ≤ +85°C	Vout ≥ 1.95V	Vout × 0.99	Vout	V
		Vout ≤ 1.9V	-20	+20	mV	
Output current	Iout	Vin ≥ Vout+1.0V	0.9V ≤ Vout ≤ 1.15V	250		mA
			1.2V ≤ Vout ≤ 1.65V	250		mA
			1.7V ≤ Vout ≤ 2.25V	250		mA
			2.3V ≤ Vout ≤ 2.85V	250		mA
			2.9V ≤ Vout ≤ 3.45V	250		mA
			3.5V ≤ Vout ≤ 4.05V	250		mA
			4.0V ≤ Vout ≤ 5.0V	250		mA
Dropout voltage	Vdrop	Iout=100mA	0.9V ≤ Vout ≤ 1.15V	480	730	mV
			1.2V ≤ Vout ≤ 1.65V	210	340	mV
			1.7V ≤ Vout ≤ 2.25V	130	205	mV
			2.3V ≤ Vout ≤ 2.85V	100	150	mV
			2.9V ≤ Vout ≤ 3.45V	90	137	mV
			3.5V ≤ Vout ≤ 4.05V	85	115	mV
			4.0V ≤ Vout ≤ 5.0V	80	85	mV
Power dissipation	Idd	Vin=Vout+1.0V, Vout=Open, Iout=0mA		25	40	μA
Standby current	Istb	EN=Open or Vss		0.01	0.1	μA
Input voltage	Vin		1.6		6.0	V
Load regulation	ΔVout	Vin=Vout+1.0V, 1mA ≤ Iout ≤ 100mA		10	40	mV
Line regulation	$\frac{\Delta V_{out}}{\Delta V_{in} \cdot V_{out}}$	Vout+1.0V ≤ Vin ≤ 6.0V, Iout=30mA		0.01	0.10	%/V
Ripple rejection	Rr	Vin=Vout+1.0V, f=1.0KHz, ΔVrip=0.5Vp-p, Iout=30mA		75		dB
Output voltage temperature coefficient	$\frac{\Delta V_{out}}{\Delta T_a \cdot V_{out}}$	Vin=Vout+1.0V, Iout=30mA, -40 ≤ Ta ≤ +85°C		±20		ppm/°C
Limit current	Ilimit	EN=Vin	300			mA
Short circuit current	Ishort	Vin=Vout+1.0V, Vout=0V		40		mA

AnaSem. InC

2-13-10 Maehara Nishi Funabashi Chiba Japan
 TEL (047) 470-5810 FAX470-5825
 Home Page: <http://www.anasem.co.jp>
 e-mail: support@anasem.co.jp